

Chapter 9 - Options

Chapter Overview

Paper Handling Options

 Optional Replacement Cassettes

 Optional 500 Sheet Cassette and Feeder

RAM Upgrades

 Installing RAM Upgrades

Ethernet Upgrade

 Installing the Ethernet Upgrade

Notes

Introduction

This chapter covers the available options for your Accel-a-Writer 812 printer. These include the paper handling options— extra cassettes and the paper feeder with a 500 sheet cassette. It also includes RAM (memory) and Ethernet upgrades.

Note: Be sure to check the README file included with your XANTÉ Utilities. If any options have become available since this manual was printed, this file will list them.

Paper Handling Options

Your Accel-a-Writer 812 offers several ways to increase its paper handling capacity and diversity. The options include replacement cassettes and a 500 sheet paper feeder with a cassette.

The standard printer comes with a 250 sheet cassette (letter or A4 size) as well as the built-in fold down tray that will handle up to 100 sheets of standard or custom size media. This not only gives you up to a 350 sheet capacity, it also provides extra flexibility. For example, if you often switch between colored stock and regular paper or between letter and legal size stock, you can load one type of media in the cassette and the other in the fold down tray.

With the addition of an optional 500 sheet cassette and feeder, you can increase the printer's capacity to 850 sheets (with the fold down tray). Plus, you gain more flexibility without switching trays. For example, you can load letterhead in the standard cassette, transparencies or envelopes in the fold down tray, and plain paper in the optional cassette.

The printer's standard fold down tray can handle up to 10 envelopes.

Optional Replacement Cassettes

You can order optional replacement cassettes in the following sizes:

250 sheet cassettes

letter

A4

multi-size (letter, legal, A4, executive, B5)

500 sheet cassettes

multi-size (letter, legal, A4, executive, B5)

multi-size (letter, A4, executive, B5)

Note: If you use a multi-size universal cassette, you should install the universal cassette cover. This cover prevents dust and debris from getting into the cassette and building up in the printer where it can reduce print quality. See “Feeding Media to the Printer” in chapter 6 for installation details.

The next section covers setting up the 250 sheet cassettes. See “Optional 500 Sheet Cassette and Feeder” later in this chapter for details on setting up and loading a 500 sheet cassette.

Optional 250 Sheet Cassette

The letter and A4 size 250 sheet cassettes install in the same manner as the standard cassette. See “Loading the Paper Cassette” in chapter 2 for details.

Use the following procedure to set up a 250 sheet multi-size cassette.

1. Unpack the cassette.

2. Check the paper length and width guides (fig. 9.1). If they are set for the size media you are going to use, skip to step 3. If not, use the following procedure to reposition the guides.
 - a. If the length guide is not positioned for the desired size, slide it to the right, lift it up and out. If the width guide is not positioned for the desired size, slide it forward and lift it up and out (fig. 9.1).

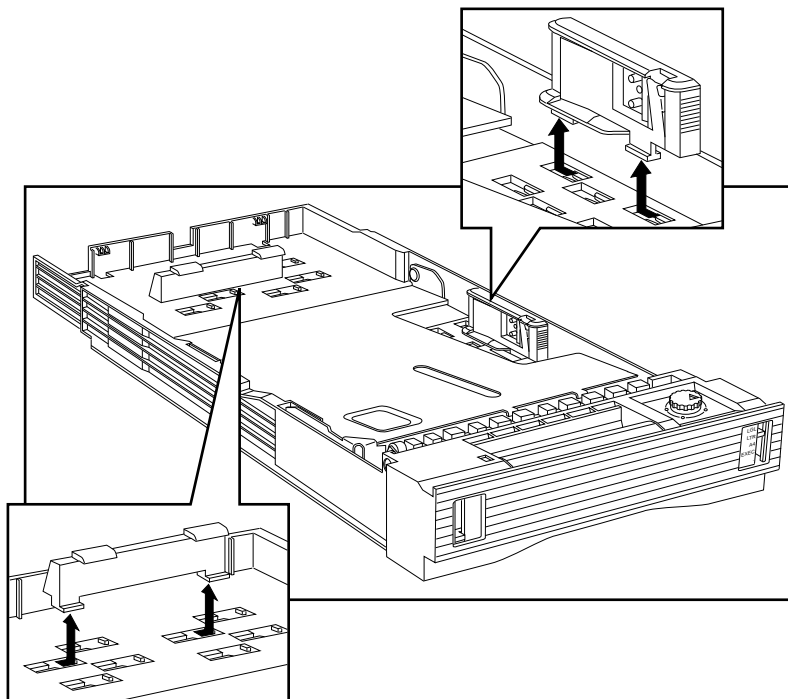

Fig. 9.1 Remove the Paper Size Guides

- b. Replace the length guide by placing it in the slots for the desired length and sliding it to the left until it locks in place (fig. 9.2). Replace the width guide by placing it in the slots for the desired width and sliding it back until it locks in place (fig. 9.2).

Note: If you are using legal size media, store the paper length guide in the slot at the front of the cassette.

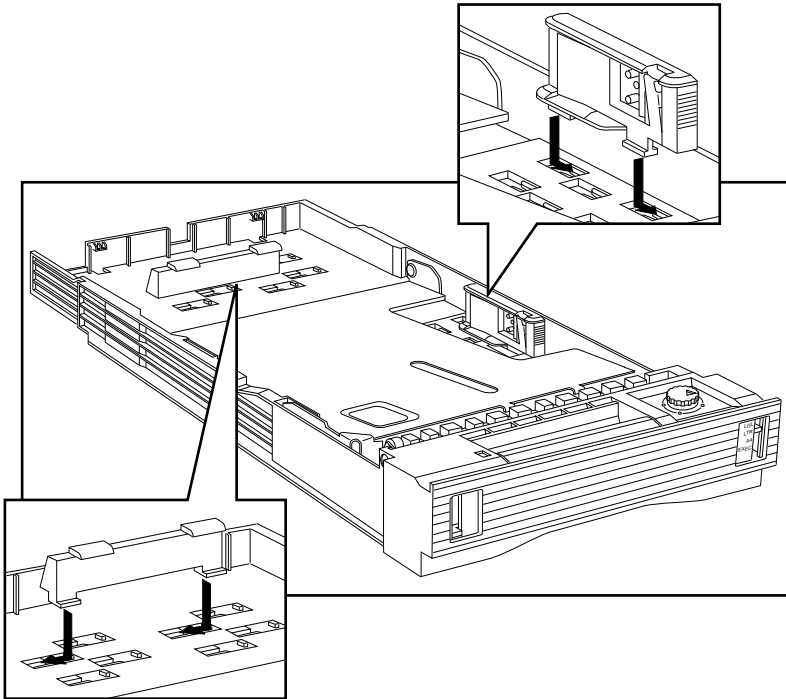

Fig. 9.2 Replace the Paper Size Guides

3. Prepare and load media into the cassette in the same manner as you do for the standard paper cassette. See “Loading the Paper Cassette” in chapter 2 for details.

4. Set the paper size dial to the size of the media loaded in the cassette (fig. 9.3). Then make sure the paper size indicator on the end of the cassette matches the setting.

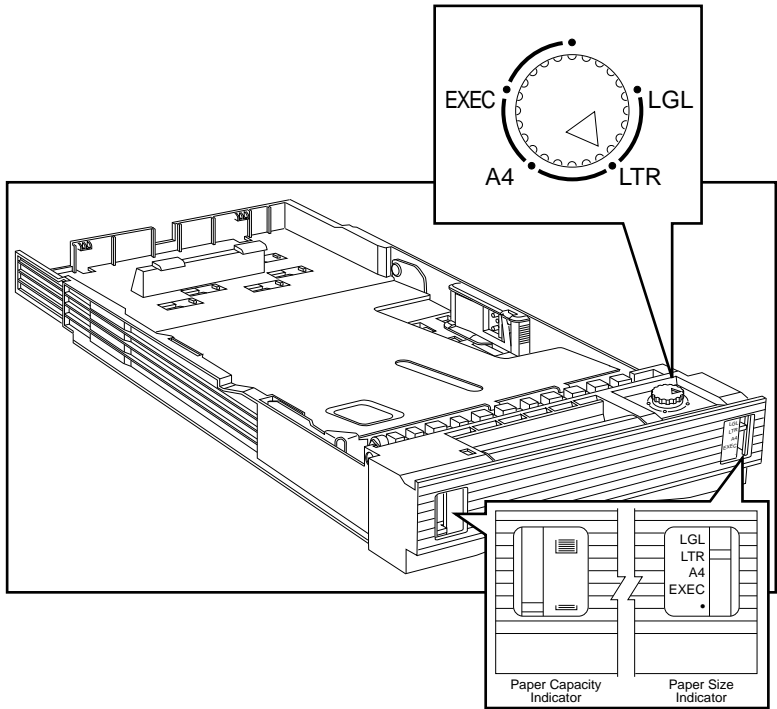

Fig. 9.3 Set the Paper Size Dial and Check the Paper Size Indicator

Note: The paper capacity indicator shows how much media is loaded in the cassette (fig. 9.3).

Optional 500 Sheet Cassette and Feeder

With the addition of the optional paper feeder, a second paper cassette can be added to your printer. This provides versatility. For example, if you use both letter and executive size paper, you can load 250 sheets of letter paper in one cassette and 500 sheets of executive paper in the second one used with the feeder. Plus, you still have the fold down tray where you can load a third size of paper.

For more details on the feeder, see “Using the Optional Paper Feeder” in chapter 6.

Installing the 500 Sheet Cassette and Feeder

Use the following procedure to install the 500 sheet cassette and its feeder.

1. Unpack the cassette and its feeder, placing the feeder next to the printer and the cassette aside for now.
2. Turn off your printer and disconnect the power cord and all interface cables.

Warning! The printer weighs approximately 43 lbs (19.4 kg) with the toner and a cassette loaded. Have someone help you lift it.

3. With the help of someone else, align the printer over the feeder and gently lower it onto the feeder (fig. 9.4).

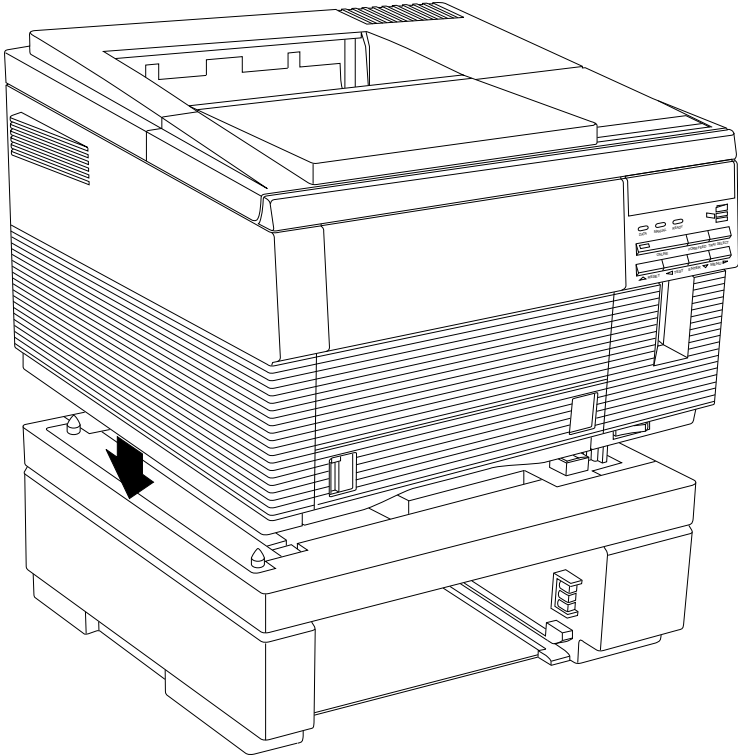

Fig. 9.4 Lower the Printer onto the Feeder

4. Check the paper length guide (fig. 9.5). If it is not positioned for the desired length, lift the length guide up and out. Then, place it in the slots for the desired length, making sure it seats firmly into place.
5. Check the paper width guide (fig. 9.5). If it is not positioned for the desired media width, squeeze the green latch on outside of the guide, slide the guide in or out to the desired width, and release the latch.

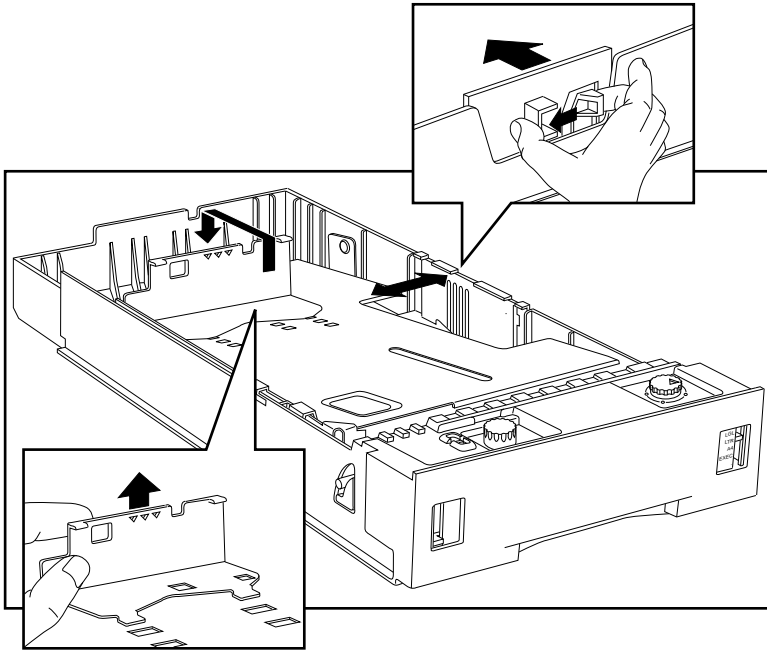

Fig. 9.5 Adjust the Paper Length and Width Guides

6. Prepare and load media into the cassette in the same manner as you do for the standard paper cassette. See “Loading the Paper Cassette” in chapter 2 for details.

7. Set the paper size dial to the size of the media loaded in the cassette (fig. 9.6). Then make sure the paper size indicator on the end of the cassette matches the setting.
8. Adjust the paper capacity indicator for the amount of media loaded in the cassette (9.6). The blue gauge to the left should be aligned in the center for proper tension on the media.

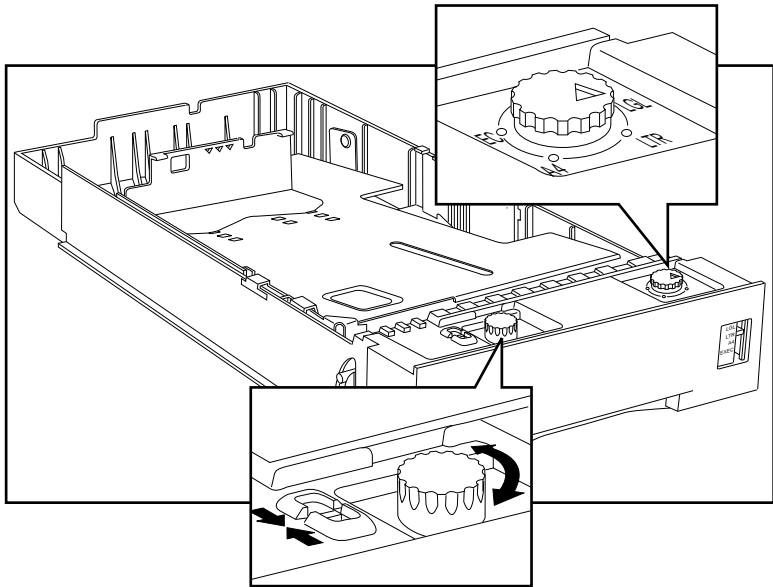

Fig. 9.6 Set the Paper Size and Paper Capacity Dials

9. Slide the loaded cassette into the cassette feeder.
10. Reconnect the power cord and all interface cables.
11. Turn on your printer.

You now have two available paper cassettes. If the cassettes are the same size, you can chain them so when one empties, the printer automatically draws from the second one. For details, see “Tray Chaining” in chapter 6.

Note: If you try to chain the two cassettes with different size media in each, you will get a PAPER OUT message when the first cassette is empty.

RAM Upgrades

Your Accel-a-Writer 812 comes with 16 MB of standard RAM (Random Access Memory) which can be upgraded to a maximum 64 MB. These upgrade modules allow the printer to handle larger, more complex graphics and text files with more downloaded fonts.

The Accel-a-Writer 812 will accept 4, 16, or 32 MB SIMMs (Single In-line Memory Module). The 4 MB upgrades are 72 pin SIMMs, arranged as a 1 MBit by 32 bit width. The 16 MB upgrades are arranged as a 4 MBit by 32 bit width. The 32 MB upgrades are arranged as an 8 MBit by 32 bit width. We recommend SIMMs with a speed of 60 ns.

The RAM configuration must be set in one of the following combinations:

<u>Total RAM</u>	<u>SIMM Combinations</u>
16 MB	16 MB
20 MB	16 MB and 4 MB
32 MB	16 MB and 16 MB
48 MB	32 MB and 16 MB
64 MB	32 MB and 32 MB

Installing RAM Upgrades

Required Tools:

- A small magnetized Phillips screwdriver
- An antistatic wristband

Caution: Static electricity can destroy circuit boards, such as your controller board and SIMM (RAM) upgrades. Be sure to wear the anti-static wristband.

Use the following procedure to install the RAM upgrade.

1. Put on the anti-static wristband following the directions on the package.
2. Turn off your printer and disconnect the power cord and all interface cables.
3. Open the top cover by pressing in on the raised finger grips on each side and lifting up and back approximately 180° (fig. 9.7).

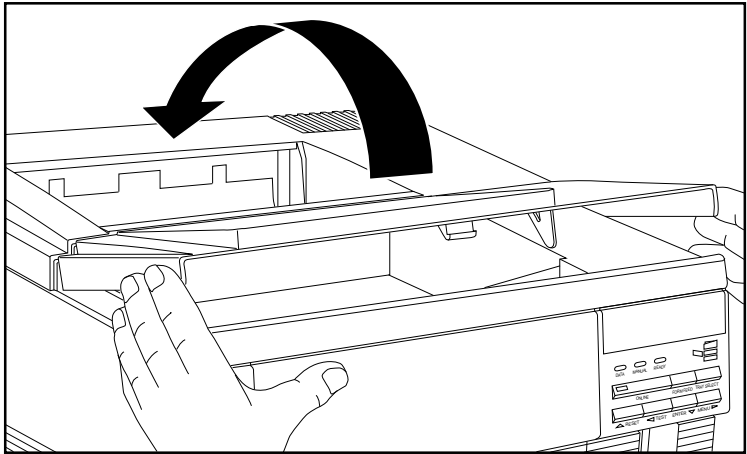

Fig. 9.7 Open the Top Cover

4. Locate and remove the side cover securing screw located on the back of the printer just below and to the left of the interface plate (fig. 9.8).
5. Slide the side cover toward the back of the printer (fig. 9.8).

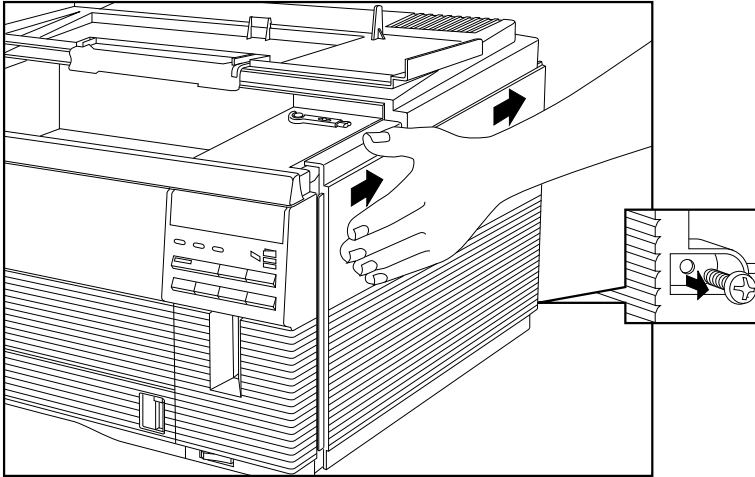

Fig. 9.8 Remove the Securing Screw and Slide the Side Cover Back

6. Remove the side cover by lowering it and gently lifting the bottom edge up and out of the slots on the printer. Then, set the cover aside for now (fig. 9.9).

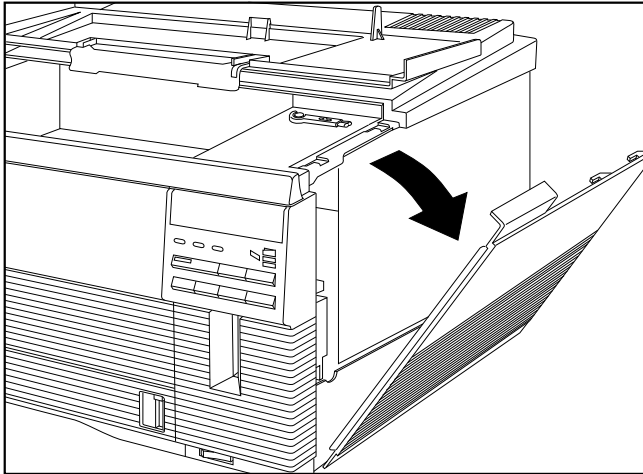

Fig. 9.9 Remove the Side Cover

7. Remove the 9 screws securing the EMI shield to the printer (fig. 9.10).

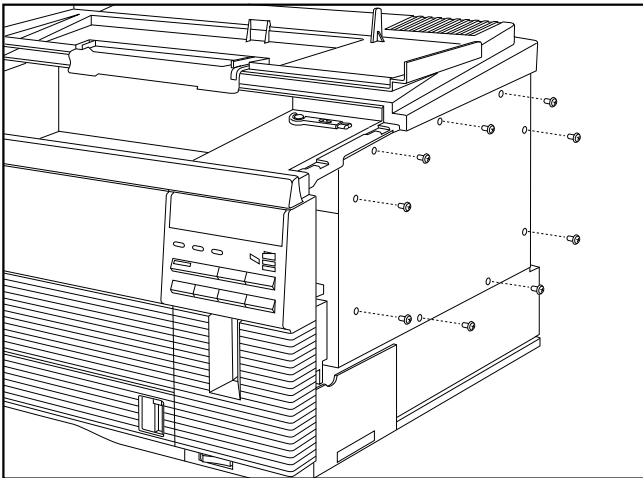

Fig. 9.10 Remove the EMI Shield Screws

8. Tilt the EMI shield down and lift the tabs at the bottom out of the slots on the printer (fig. 9.11). Then, set the shield aside for now.

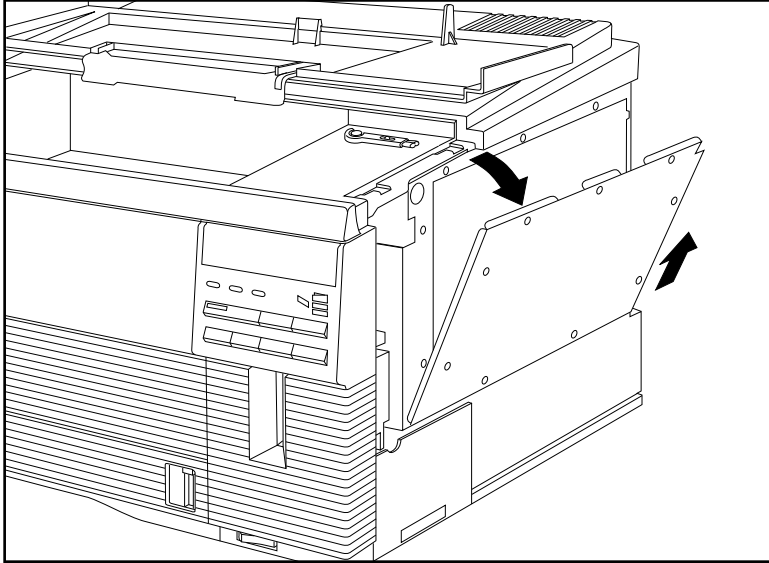

Fig. 9.11 Remove the EMI Shield

9. Locate the RAM banks on the controller board (fig. 9.12).

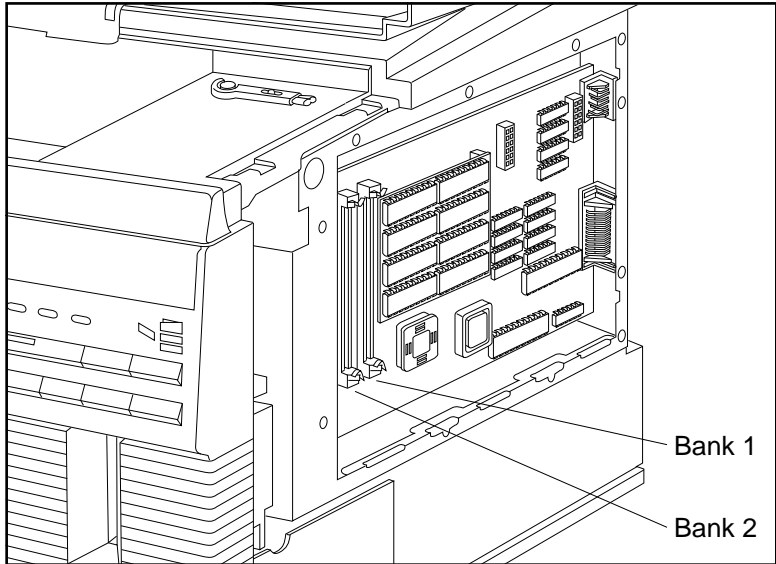

Fig. 9.12 Locate the Controller Board RAM Banks

10. Install the RAM upgrade using the following procedure.

Note: RAM banks must be filled in order, Bank 1 and then Bank 2. If you mix SIMM RAM sizes, the larger size SIMM goes into Bank 1 and the smaller in Bank 2.

- a. If Bank 2 is open and the upgrade SIMM is the same size or smaller than the SIMM in Bank 1, skip to step d.
- b. Use your thumbs to pull open the two latches on the bank, one on each end (fig. 9.13).

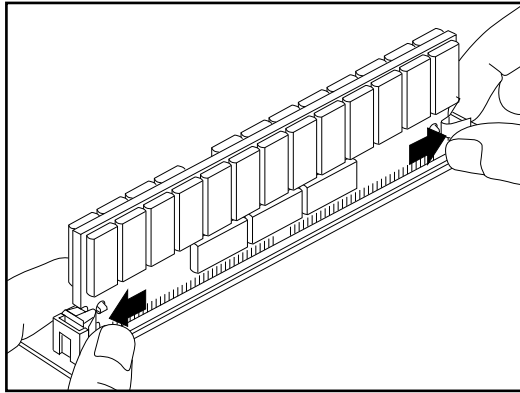

Fig. 9.13 Open the Bank Latches

- c. Tilt the SIMM to be removed forward towards you to a 45° angle and slide it up and out of the bank (fig. 9.14).
- d. Remove the upgrade SIMM from its protective bag.
- e. Align the new SIMM with the notched corner down and the SIMM tilted to the right at a 45° angle to the controller board over the appropriate bank (fig. 9.14). Then insert the SIMM into the bank's connector.

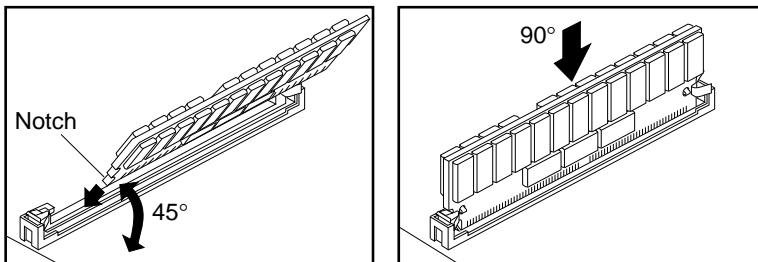

Fig. 9.14 Installing a SIMM

Caution: A SIMM only fits in one direction. Do not force a SIMM in place. If it does not go in easily, realign it making sure that the notched corner is down and that the SIMM seats correctly in the bank.

- f. Gently push the SIMM toward the left and up to a 90° angle (fig. 9.14) with the controller board until the two bank latches snap in place in front. You may have to hold the two latches out while pushing the SIMM into place, and then release them. If you do not have another SIMM to install, skip to step 10.
 - g. If you have another SIMM to install repeat steps a through f.
11. Replace the EMI shield by placing the tabs on the bottom into the slots on the printer and tilting it up into position (fig. 9.15).

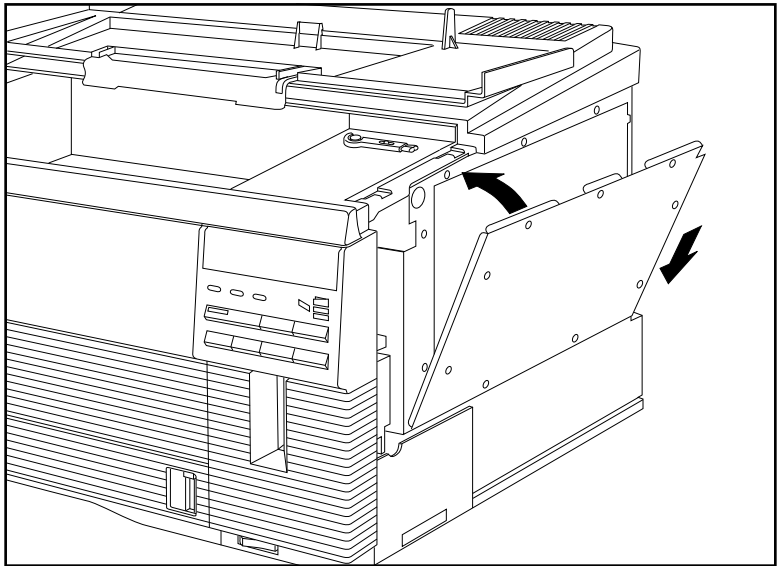

Fig. 9.15 Replace the EMI Shield

12. Replace the 9 screws securing the EMI shield (fig. 9.16).

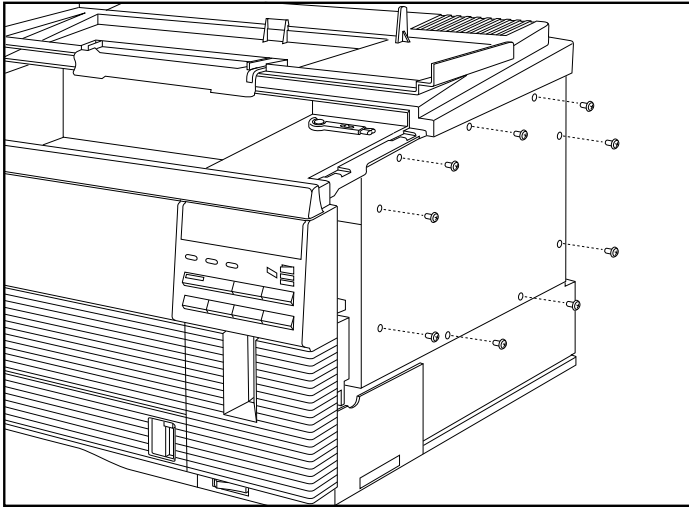

Fig. 9.16 Replace the EMI Shield Screws

13. Replace the side cover by slipping the tabs on the bottom edge into the slots on the printer and raising the cover back up (fig. 9.17).

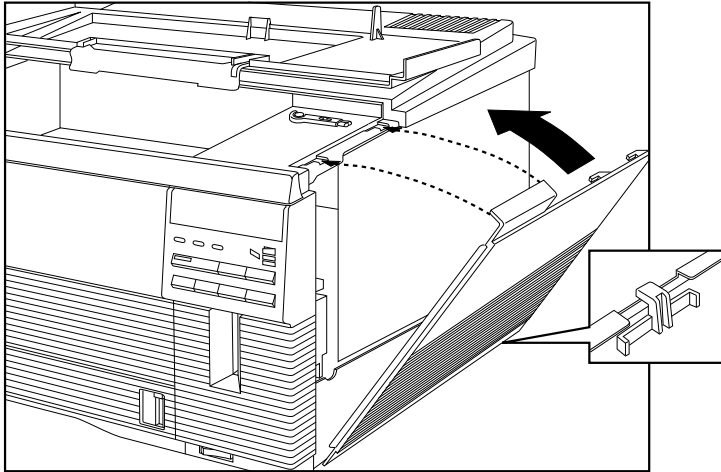

Fig. 9.17 Replace the Side Cover

- Slide the side cover back into position by pushing it toward the front of the printer (fig. 9.18).

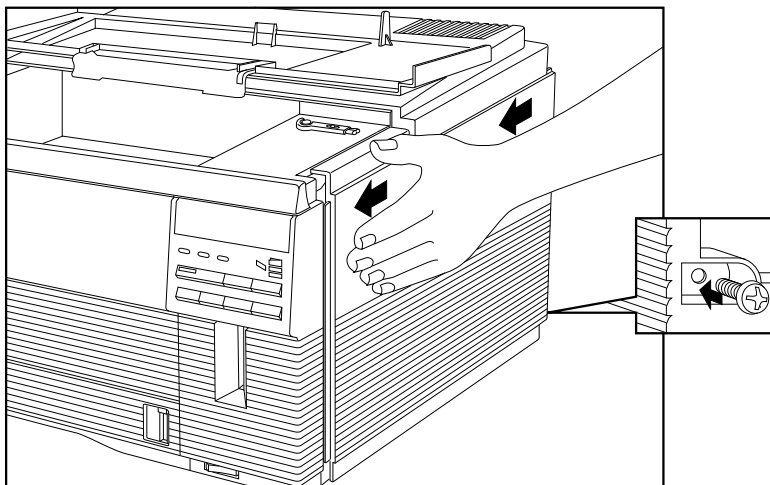

Fig. 9.18 Position the Side Cover

- Replace the side cover screw on the back of the printer just below and to the left of the interface plate.
- Close the top cover.
- Reattach the interface cables and power cord.
- Turn on your printer.

Note: If you want to confirm the memory upgrade, check the start-up page. To print a test start-up page, take the printer off line and press the Test key. Then check the page for the amount of RAM listed.

Ethernet Upgrade

The Ethernet upgrade is designed to support EtherTalk and TCP/IP protocols in an Ethernet environment on thinnet coax (10Base2) or twisted-pair (10BaseT). XANTÉ's EtherTalk interface is designed to work on Ethernet.