

Chapter 2 - Installation

Chapter Overview

Printer Location

Package Contents

Printer Setup

 Unpacking the Printer

 Installing Options

 Installing the Toner Cartridge

 Loading the Paper Cassette

 Loading the Fold Down Tray

 Connecting the Power Cord

 Starting the Printer

Printing the Start-up Page

Selecting an Interface

 Connecting in a Macintosh Environment

 Connecting in a PC Environment

 Connecting to Ethernet

 Connecting a Hard Disk

Notes

Introduction

This chapter covers setting up your new Accel-a-Writer 8200 printer. It includes finding the right location, unpacking the printer, installing toner and paper, connecting the power cord, printing a start-up page, and connecting to an interface.

Printer Location

Before unpacking your Accel-a-Writer 8200, you need to choose a good location. This area should meet the following guidelines:

- Be on a level, sturdy surface capable of supporting 60 lbs (27.24 kg)
- Have an area of approximately 25" x 49" (644 mm x 1250 mm) so there is sufficient clearance for operation and maintenance
- Maintain a temperature of 50° to 90.5° Fahrenheit (10° to 32.5° Celsius) without rapid changes
- Maintain a relative humidity between 20% and 80%
- Be away from direct sunlight, open flames, refrigerators, water faucets, humidifiers, heaters, or similar equipment
- Be away from strong vibrations or electromagnetic fields
- Maintain proper host-printer distance for communication: within 10 feet (3 m) for parallel; within 25 feet (7.5 m) for serial; within 1000 feet (305 m) for LocalTalk
- Be close to a grounded electrical outlet with the proper voltage

Note: Do not use ammonia-based cleaners on or around the printer; they react chemically with the toner. Also, like most laser printers and photocopiers, this one produces a small amount of ozone, so choose a well ventilated area.

Package Contents

Your printer package, which you have opened already, contains the following items:

- Accel-a-Writer 8200 printer
- 250 sheet letter or A4 paper cassette
- 250 sheet ledger (11" x 17") or A3 paper cassette
- Cassette cover
- Power cord
- *Accel-a-Writer 8200 User's Guide* (this manual)
- XANTÉ Utilities, PSPrinter driver, and other software disks
- Toner cartridge for the Accel-a-Writer 8200 (EP-BII)*

* If you purchased the printer with the extra wide print option, the printer ships with the EP-BIIX extra wide toner cartridge.

Optional items from the following list ship separately.

- Additional 250 sheet paper cassettes
- Paper feeder
- Cassette supporter
- 500 sheet letter/A4 paper cassette

Note: If you order optional RAM, Ethernet, or resolution upgrades when you order your printer, they will be installed before the printer ships.

If you do not receive your full shipment or if anything is damaged, immediately contact XANTÉ Customer Support at 800-926-8393 in the US and Canada, at 95-800-926-8393 Mexico or at (334) 342-4846 elsewhere.

Printer Setup

Printer setup includes

- Unpacking the printer
- Installing optional equipment
- Installing the toner cartridge
- Loading the paper cassette
- Loading the fold down tray
- Connecting the power cord
- Starting the printer

Before you begin this setup, take a few minutes to look over figures 2.1 and 2.2 to familiarize yourself with the printer.

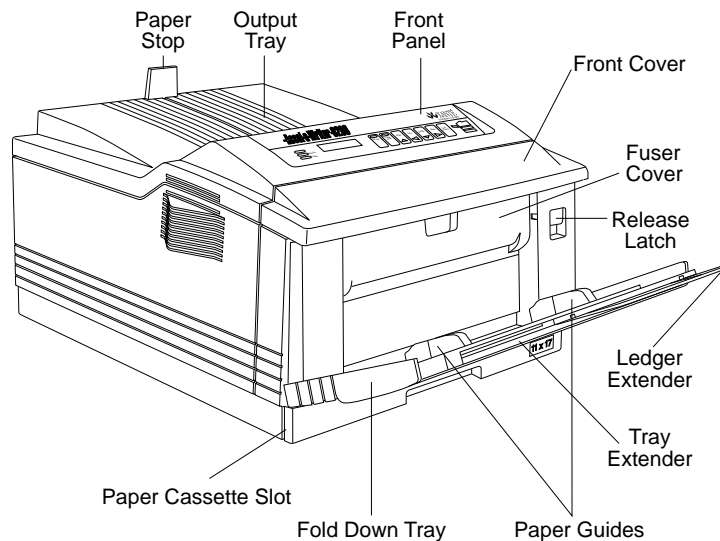

Fig. 2.1 Front View of the Printer

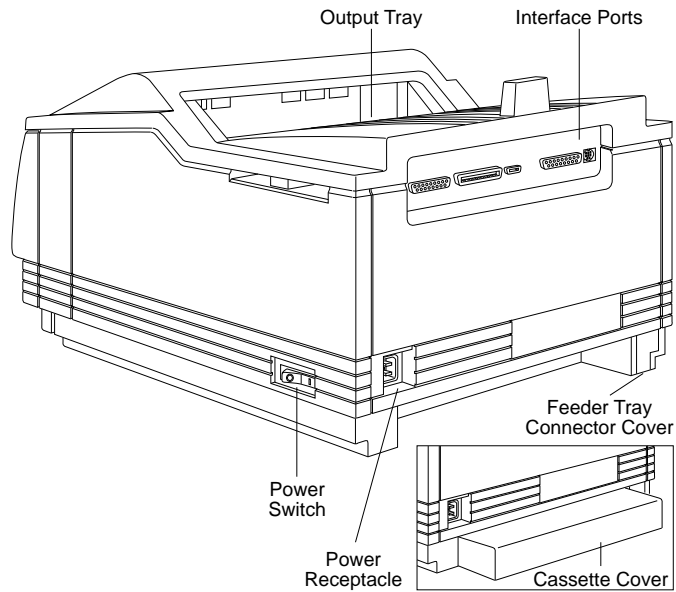

Fig. 2.2 Rear View of the Printer

Unpacking the Printer

Various packing materials protect your printer during shipping. These materials include plastic, tape, polystyrene, cardboard, and shipping spacers—all of which must be removed. You may want to save these materials in case you ever have to move or ship the printer.

1. Remove everything except the printer in its protective bag from the shipping box.

Warning! The printer weighs approximately 51 lbs (23 kg) without the toner, cassettes, and media installed. Have someone help you lift it.

2. Lift the printer out of the box.
3. Remove the plastic wrap from around the printer.

4. Remove the three pieces of tape securing the fold down tray. The tape is located at the top and on each side of the tray.
5. Open the fold down tray by grasping the top corners and pulling out and down (fig. 2.3).

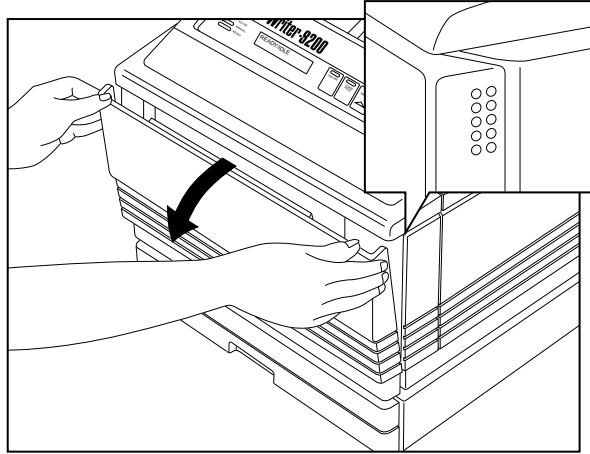

Fig. 2.3 Open the Fold Down Tray

6. Locate the shipping cardboard in the lower right corner of the front cover. Then, pull it straight out to remove it (fig. 2.4).

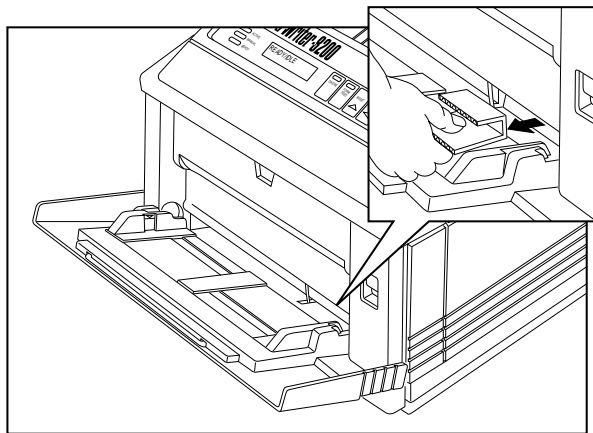

Fig. 2.4 Remove the Shipping Cardboard

7. Open the front cover by lifting the release latch and tilting the cover towards you (fig. 2.5).

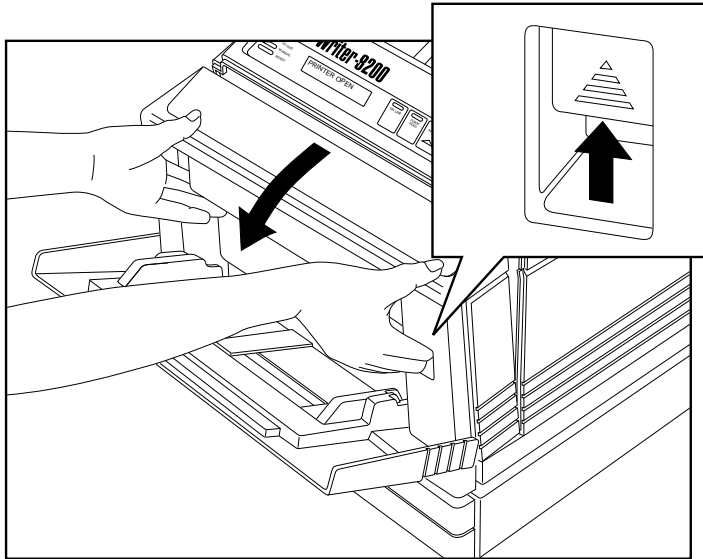

Fig. 2.5 Open the Front Cover

8. Remove the two orange shipping spacers by pulling them up and back in the direction of the arrows (fig. 2.6).

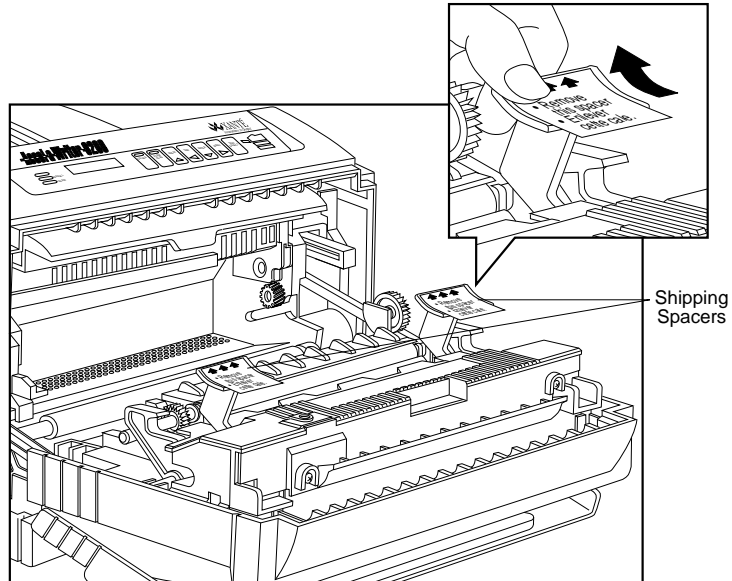

Fig. 2.6 Remove the Two Shipping Spacers

If you did not purchase the optional paper feeder or the 500 sheet letter/A4 paper cassette with the cassette supporter, skip to “Installing the Toner Cartridge.”

Installing Options

If you have an optional paper feeder or the 500 sheet letter/A4 paper cassette with the cassette supporter, unpack the option(s) now. Follow the installation instructions included with the option(s). See “Tray Chaining” in chapter 6 for details on using optional trays.

Installing the Toner Cartridge

Caution: The toner cartridge is sensitive to bright lights and direct sunlight. Leave it in its protective bag until you are ready to load it into the printer. The cartridge contains a magnet, so keep it away from your hard disk(s) and monitor to prevent possible data loss or equipment damage.

The standard Accel-a-Writer 8200 ships with an EP-BII toner cartridge. If you purchased the extra wide print option with your printer, it ships with the EP-BIIX extra wide cartridge. Both cartridges load in the same manner.

Use the following procedure to install the toner cartridge.

1. If the fold down tray is closed, open it by grasping the top corners and pulling out and down (fig. 2.3).
2. If the front cover is closed, open it by lifting the release latch and tilting the cover towards you (fig. 2.5).
3. Remove the toner cartridge from its package and gently rock it back and forth to distribute the toner evenly throughout the cartridge (fig. 2.7).

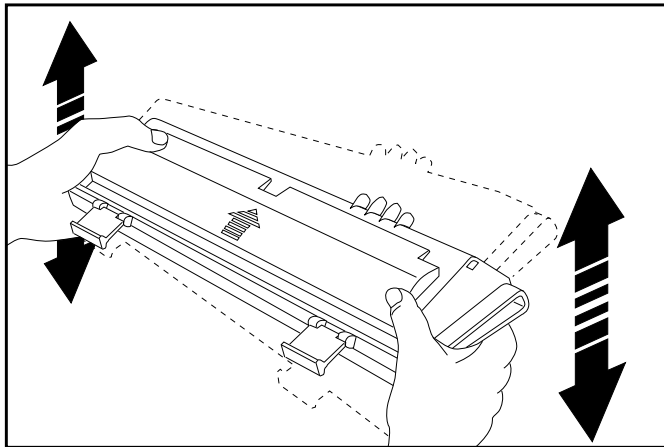

Fig. 2.7 Distribute the Toner

4. Grasp the center tab labeled “Remove the black sheet slowly” and gently pull out and discard the protective black plastic sheet from the toner cartridge (fig. 2.8).

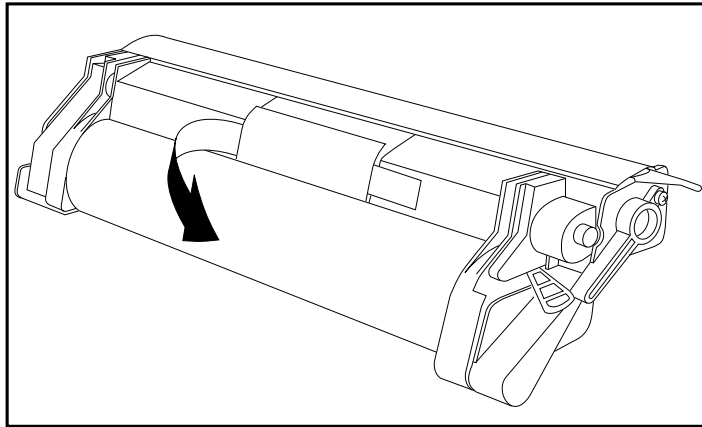

Fig. 2.8 Remove the Plastic Protective Sheet and Tape

5. Gently flex the orange tab on the end of the sealing tape back and forth until it becomes loose. Then, pull the tab and tape from the toner cartridge and discard it (fig. 2.9).

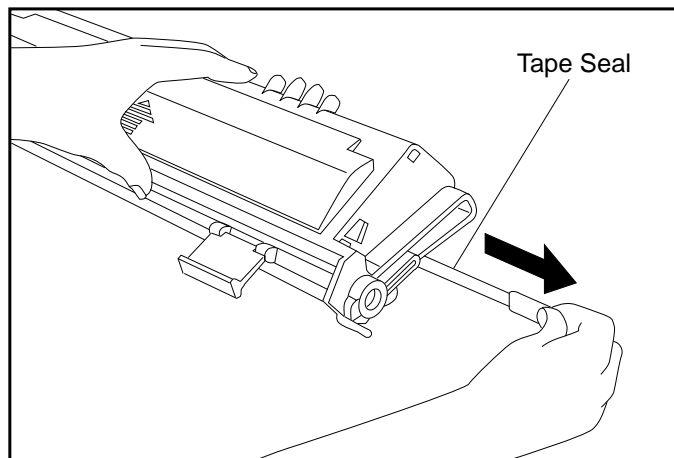

Fig. 2.9 Remove the Toner Sealing Tape

6. Holding the toner cartridge by the two green tabs (fig. 2.10), align it on the runners inside the printer, and slide the cartridge into the printer until it rests securely in place.

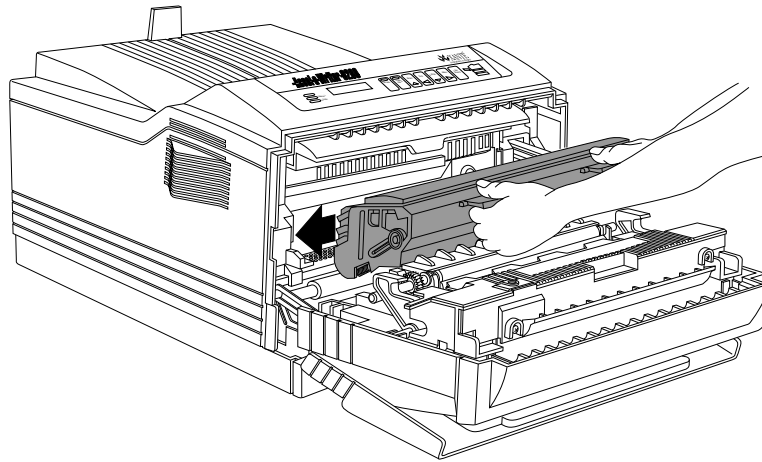

Fig. 2.10 Load the Toner Cartridge

7. Close the printer's front cover until it clicks in place.
8. Close the fold down tray.

Note: Never move or ship the printer with a toner cartridge installed.

Loading the Paper Cassette

Two 250 sheet paper cassettes (one letter/A4 and one ledger (11" x 17")/A3) ship with your Accel-a-Writer 8200. This section includes instructions for loading the letter/A4 size cassette with laser quality or 20 lb photocopier paper.

Refilling a cassette, printing on other types of media (transparencies, labels, and envelopes), and printing on other sizes are covered in chapter 6, "Routine Operations." That chapter also covers selecting and storing media.

Use the following procedure to load the letter/A4 cassette.

1. Pull the paper cassette straight out from the printer (fig. 2.11).

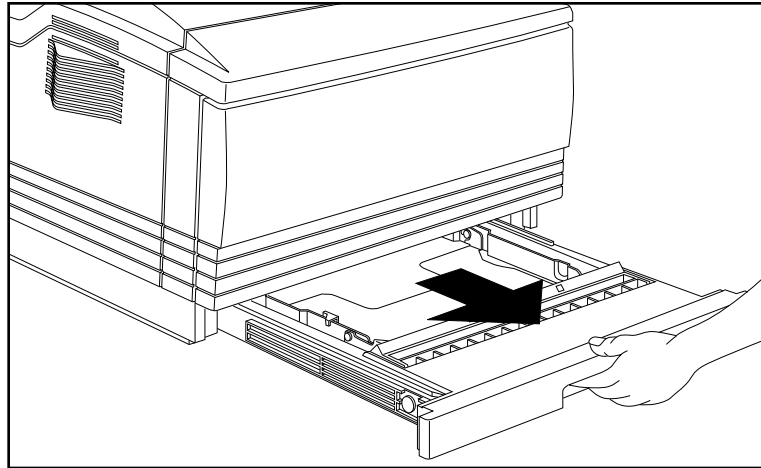

Fig. 2.11 Remove the Paper Cassette

2. Prepare up to 250 sheets (approximately 1" [25 mm] thick or less) of laser quality or 20 lb photocopier paper. To do this:
 - a. Make sure the paper meets all the requirements in "Selecting Media" in chapter 6.
 - b. Determine the printing side of the paper. The wrapper on most paper packages has an arrow pointing in the direction of the printing side.
 - c. Fan the paper to prevent it from sticking together, and then align the edges to form a smooth stack.

- Slide the paper printing < de up, long edge first under the two plastic clips at the rear of the cassette and the two metal clips at the front corners of the cassette.

Caution: Make sure the paper stack does not exceed the upper paper limit marked on the cassette (fig. 2.12). Overloading a cassette will cause paper to jam.

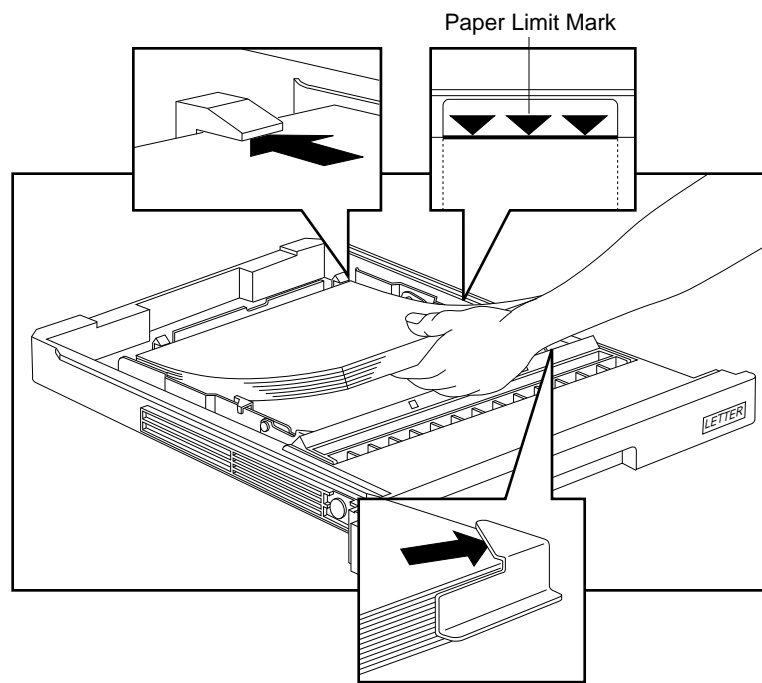

Fig. 2.12 Load the Paper Cassette

4. Adjust the paper stop on the output tray for the size media you are using (fig. 2.13).

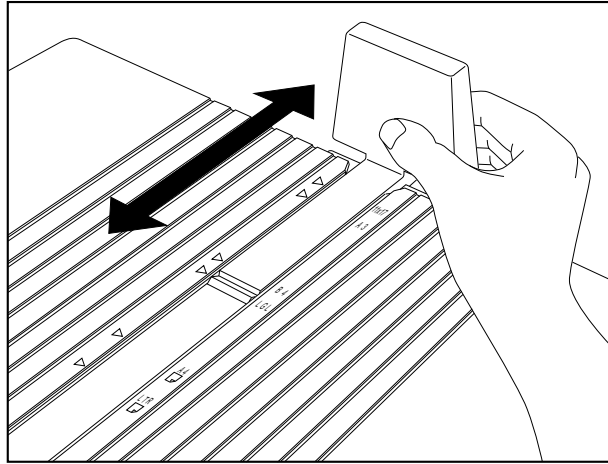

Fig. 2.13 Adjust the Paper Stop

5. Slide the cassette into the printer until it snaps into place.

Note: If you install the ledger (11" x 17")/A3 paper cassette, you should install the rear cassette cover. For cover installation details, see "Feeding Media to the Printer" in chapter 6.

Loading the Fold Down Tray

Your Accel-a-Writer 8200 has a built-in fold down tray on the front. You can use the tray to feed up to 100 sheets of standard letter/A4, legal/special A4, or ledger (11" x 17")/A3 sized media. You also can use the tray to feed envelopes and variable custom sized media measuring between 3.90" to 5.80" (99 mm x 147 mm) and 11.81" to 25.00" (300 mm x 635 mm).

Note: With the extra wide print option, you can print 12.00" x 19.00" and 12.00" x 25.00" paper with respective print regions of 11.97" x 18.93" and 11.97" x 24.93" using the fold down tray.

This section includes instructions for loading letter/A4 size laser quality or 20 lb photocopier paper. Refilling the tray, printing on other types of media (transparencies, labels, and envelopes), and printing on other sizes are covered in chapter 6.

Use the following procedure to load the fold down tray.

1. Open the fold down tray by grasping the top corners and pulling out and down (fig. 2.14).

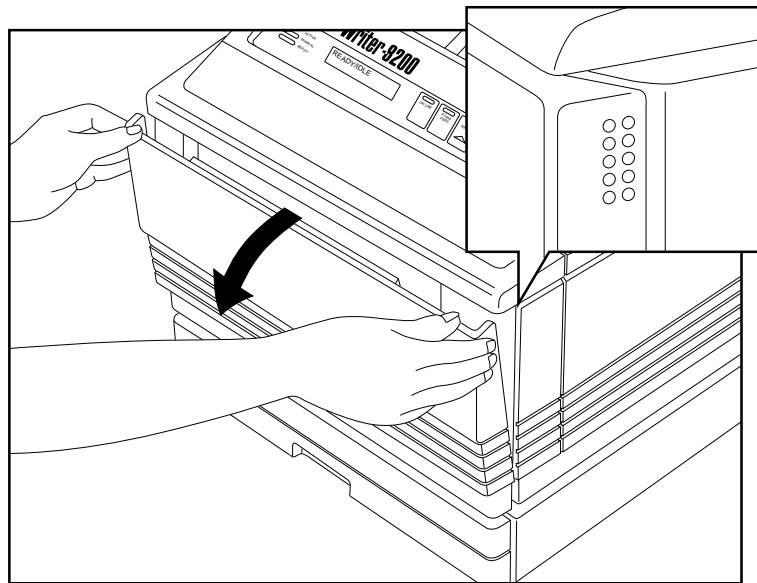

Fig. 2.14 Open the Fold Down Tray

2. Pull out the tray extender (fig. 2.15).

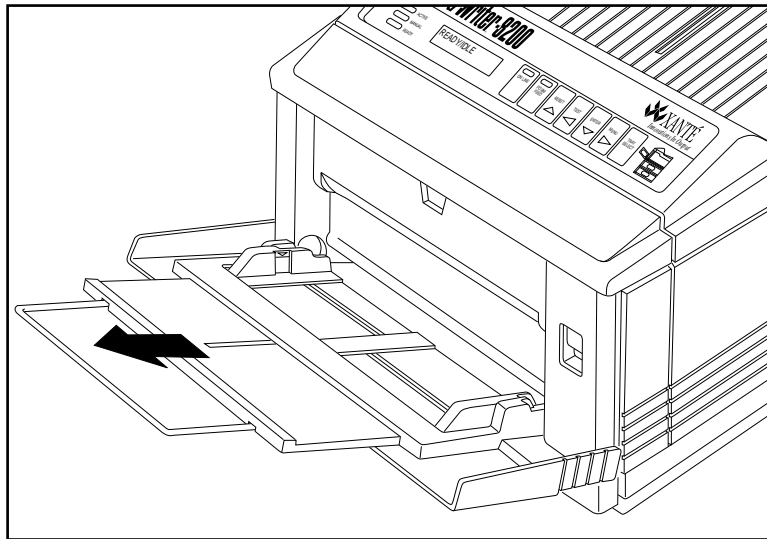

Fig. 2.15 Pull Out the Tray Extender

3. Prepare up to 100 sheets (approximately 3/8" [10 mm] or less) of laser quality or 20 lb photocopier paper. To do this:
 - a. Make sure the paper meets all the requirements listed in "Media Handling" in chapter 6.
 - b. Determine the printing side of the paper. Most packages of paper have an arrow pointing in the direction of the printing side on the wrapper.
 - c. Fan the paper to prevent it from sticking together, and then align the edges to form a smooth stack.

- Slide the paper printing side down into the fold down tray (fig. 2.16).

Caution: Make sure the paper stack does not exceed the upper paper limit marked on the tray (fig. 2.16). Overloading the tray will cause paper to jam.

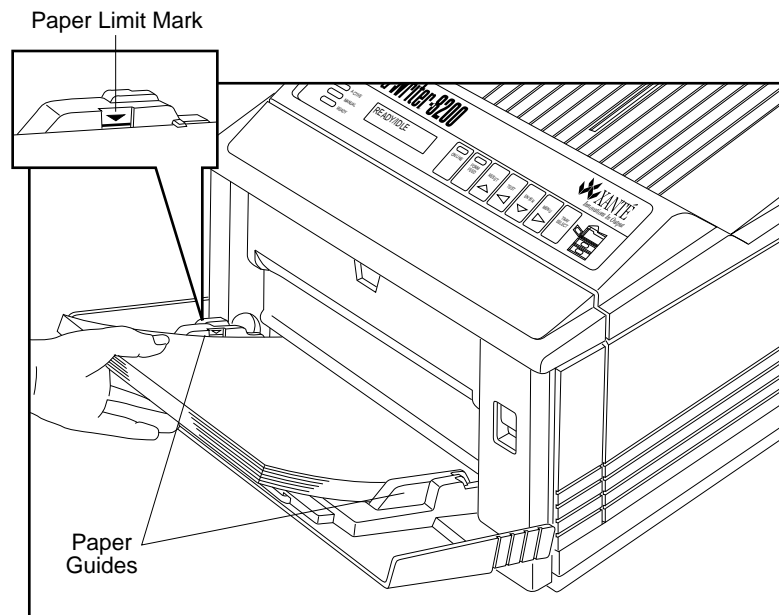

Fig. 2.16 Load the Fold Down Tray

- Adjust the paper guides on each side so they rest lightly against the paper without causing it to buckle (fig. 2.16).
- Adjust the output tray's paper stop for the size media you are using (fig. 2.13).

Connecting the Power Cord

The power connector is on the back of the printer at the lower left.

1. Make sure the printer's power switch is off (the **O** is pressed in).
2. Connect one end of the power cord to the printer.
3. Connect the other end of the power cord to a standard electrical outlet (grounded AC outlet).

Note: You may want to use a surge protected outlet to help prevent power source fluctuations from damaging your printer. Surge protectors are available through most office supply and computer stores.

Starting the Printer

The power switch is on the lower left side of the printer.

1. Locate the power switch.
2. Press the | on the power switch to turn on the printer. The green Ready light will begin flashing and Accel-a-Writer appears in the display window.

After the printer is powered on, it goes through a warm-up period of approximately 90 seconds. During this time the printer runs initializing programs and self-tests. After the warm-up period, the Ready light stops flashing and remains on. The start-up page automatically prints. See the next section, "Printing the Start-up Page," for details on this page.

If your printer does not power on when you turn the switch on, check the following:

- Is the AC power cord attached properly?
- Is the power switch in the ON position?

Printing the Start-up Page

When you turn the printer on for the first time, it prints a start-up page in approximately 90 seconds. The printer does not have to be attached to a host to print this page.

Note: Printing time for the start-up page varies depending on the selected printing resolution. The lower the resolution, the faster the start-up page prints.

The start-up page contains configuration information concerning your printer. This information includes the printer name, RAM size, page count, resolution, hard disk information, and the current firmware version.

This page prints each time you start the printer unless you disable it. Use the front panel or XANTÉ Command Center to disable this feature.

If you decide to disable this page, make sure to keep a copy for reference in case you want to check your printer setup. To disable this feature, see “Turning the Start-up Page Off or On” either in chapter 3 for a Macintosh environment or chapter 4 for a PC environment.

Selecting an Interface

Once the printer is set up, you need to select an interface to connect the printer to the host. Your Accel-a-Writer 8200 has three standard interface ports on the back—LocalTalk, serial, and parallel. There is a SCSI port where you can attach multiple external hard disks, and an optional Ethernet port.

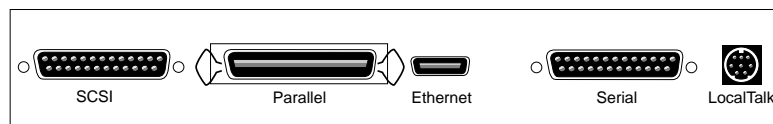

Fig. 2.17 Accel-a-Writer 8200 Ports

The serial, parallel, LocalTalk, and (optional) EtherTalk ports are simultaneously active, which allows you to access the printer through multiple ports at the same time. The printer prints the first incoming job. When the first job finishes, the next job (in the order received) prints, and so forth until all jobs print.

The port you should select depends on many variables, such as your type of host, the available host ports, your software application, printer drivers, and emulations.

Caution: DO NOT confuse the serial and SCSI interface ports when connecting cables. This will cause permanent printer damage which is not covered under the warranty. The printer ports are labeled clearly.

If you have an Ethernet setup, skip to “Connecting to the Ethernet Port” later in this chapter. If you have a PC setup, skip to “Connecting in a PC Environment” later in this chapter. If you have a Macintosh setup without Ethernet, go to the next section, “Connecting in a Macintosh Environment.”

Connecting in a Macintosh Environment

In the Macintosh environment without Ethernet, your host system communicates with the printer via the LocalTalk port.

Connecting to the LocalTalk Port

You will need two LocalTalk connector boxes with DIN-8 connectors, a standard phone cable (RJ-11), and two terminators.

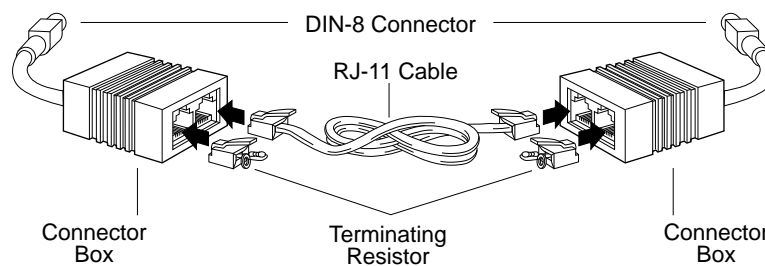

Fig. 2.18 Connecting to the LocalTalk port

To connect your printer via the LocalTalk port, use the following procedure.

1. Turn off your printer and your host computer.
2. Plug the DIN-8 connector on one LocalTalk connector box into the 8-pin LocalTalk port on the back of the printer.
3. Plug the DIN-8 connector on the second LocalTalk connector box into the printer port on your Macintosh (refer to your Apple Macintosh manual).
4. Connect the two LocalTalk connector boxes with the RJ-11 phone cable.
5. Plug the terminating resistor(s) into the open socket(s) in the connector box(es).

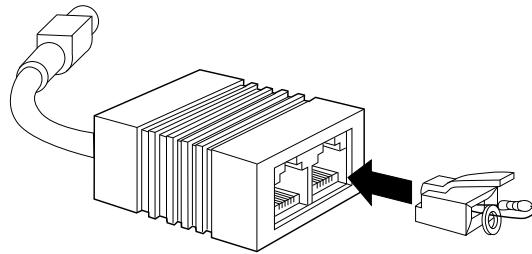

Fig. 2.19 Place a Terminating Resistor in the Open Socket

Note: Be sure to terminate the open sockets on the ends of your LocalTalk network with the terminators supplied with your LocalTalk connectors (fig. 2.19). (There should only be two open sockets on the network, one at each end.) Closing open sockets helps speed data transmission and helps ensure the printer is available in the Chooser.

6. Turn on the printer and host computer.
7. Select the Chooser from the Apple menu on your Macintosh computer. The Chooser window opens.
8. Click the appropriate LaserWriter icon in the left side of the window.

9. Select the Accel-a-Writer 8200 in the right side of the Chooser window.

If you work on a network and need to connect a second host to another printer port, skip to the section on connecting to the desired port later in this chapter. If not and you are connecting an optional hard disk, skip to “Connecting a Hard Disk” later in this chapter. Otherwise, skip to the next chapter, “Macintosh Setup.”

Connecting in a PC Environment

In a PC environment, your host system should communicate with the printer via the parallel port or serial port.

Parallel communication is faster than serial communication, but it is restricted to one-way communication from the host to the printer. Serial communication allows two-way communication between the host and printer.

Use the parallel port if your host has a Centronics parallel port available and it is within 10 ft. (3 m) of the printer. Use serial communication when a parallel port is not available on the host, if the host is between 10 ft. (3 m) and 25 ft. (7.6 m) from the printer, or if your host requires two-way communication with the printer.

If you are connecting via the serial port, skip to “Connecting to the Serial Port” later in this chapter.

Connecting to the Parallel Port

You need a standard Centronics parallel cable to connect your host and printer (fig. 2.20). The parallel port on the rear of the printer uses a 36-pin connector. The parallel port on your host computer uses a 25-pin connector.

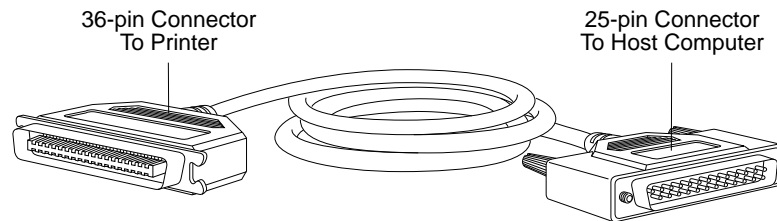

Fig. 2.20 The Parallel Cable

Use the following procedure to connect your printer and host using the parallel port.

1. Turn off your printer and host computer.
2. Plug the 36-pin connector end of the parallel cable into the parallel port on the back of the printer (fig. 2.20).
3. Plug the cable's 25-pin end into the parallel port on your host.
4. Turn on your host and then the printer.

If you work on a network and need to connect a second host to another printer port, skip to the section on connecting to the desired port later in this chapter. If not and you are connecting an optional hard disk, skip to "Connecting a Hard Disk" later in this chapter. Otherwise, skip to chapter 4, "PC Setup."

Connecting to the Serial Port

Connecting to the serial port involves two areas:

- Connecting the printer and host
- Making sure printer, host, and application settings match

You need a standard null-modem serial cable to connect your host and printer (fig. 2.21). The serial port on the rear of the printer uses a 25-pin (DB-25) connector. The serial port on your host uses either a 25-pin connector or a 9-pin connector.

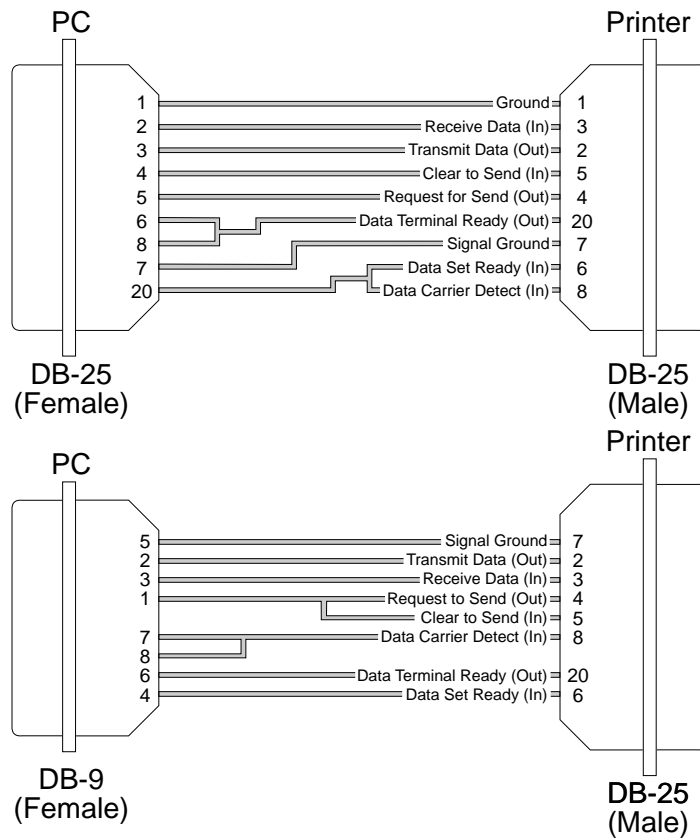

Figure 2.21 Serial Cable Pin-outs

Use the following procedure to connect your printer and host using the serial port.

Caution: DO NOT confuse the serial and SCSI interface ports when connecting the cables. This will cause permanent printer damage which is not covered under the warranty. The printer ports are labeled clearly.

1. Turn the power off to your printer and host.

2. Plug the 25-pin (DB-25) male connector end of the serial cable into the serial port on the back of your printer (fig. 2.21).
3. Plug the other end of the serial cable (with either a 25-pin or 9-pin connector) into the serial port on your host.

Now, your printer and host are connected. However, before you print, make sure your host, printer, and application are using the same communication settings. The three settings which *must* match are

- Baud Rate
- Flow Control
- Parity

The factory default printer settings are 9600 baud, XON/XOFF flow control, and No Parity (None). These settings are used in most serial printing environments.

Note: Your Accel-a-Writer 8200 always uses 8 data bits.

Baud Rate

The baud rate is the rate at which serial data is sent between the host and the printer. Your Accel-a-Writer 8200 supports 1200, 9600, and 19200 baud rates. The printer's factory default is 9600.

See your host manual for details on checking and setting up the host serial interface. You can check and set the baud rate for your Accel-a-Writer 8200 through the printer's front panel or use the procedure in "Changing Serial Communication Settings" later in this chapter. See chapter 5, "Configuration," for front panel setup information.

Flow Control

Flow control is how the printer signals the host that the printer is ready to accept data. The Accel-a-Writer 8200 supports both XON/XOFF (software) and DTR/DSR (hardware) flow control. The printer's factory default is XON/XOFF.

It is very important for both the host computer and printer to agree on flow control. Incorrect flow control causes erratic serial printing.

You can check and set the flow control through the printer's front panel or use the procedure in "Changing Serial Communication Settings" later in this chapter. See chapter 5, "Configuration," for front panel setup information.

Parity

Parity is the grouping of data bits into a uniform size. If some data is lost or damaged in transmission, chances are high that it will affect the size of a group, providing a warning of transmission errors. Your Accel-a-Writer 8200 supports five parity settings, None, Even, Odd, Mark, and Space. The printer's factory default is None. The PostScript command "setdevparams" defines the parity of the serial channel for PostScript Level 2.

Changing Serial Communication Settings

The easiest way to change serial communications is to use the printer front panel. See "Selecting Menu Options" in chapter 5 for details.

You can also change settings by creating a PostScript file and sending it to the printer. This is handy if you are networked to a printer away from your host. The following "text only" sample file changes the serial channel to 9600 baud, XON/XOFF, and None parity.

```
true 0 startjob pop
(%Serial%) <</Baud 9600 /Parity /None
/FlowControl /XonXoff>>
setdevparams
```

Now your printer and host are connected. If you are not connecting an optional hard disk, go to chapter 4, "PC Setup."

Connecting to the Ethernet Port

Two methods can be used to connect to your printer's Ethernet port. One method uses an Unshielded Twisted Pair (UTP) or 10BaseT connection, and the other uses thin coaxial cable (10Base2) connection.

Both methods require an external transceiver which is available from most computer stores or mail-order warehouses. The transceiver should have an Apple AUI (Attachment Unit Interface) connector on one end and either an Unshielded Twisted Pair (UTP or 10BaseT) cable or a thin coaxial connection (ThinNet, CheaperNet, or 10Base2) on the other end. Figure 2.22 illustrates an example of both a 10Base2 and a 10BaseT transceiver; however, designs vary slightly among transceiver brands.

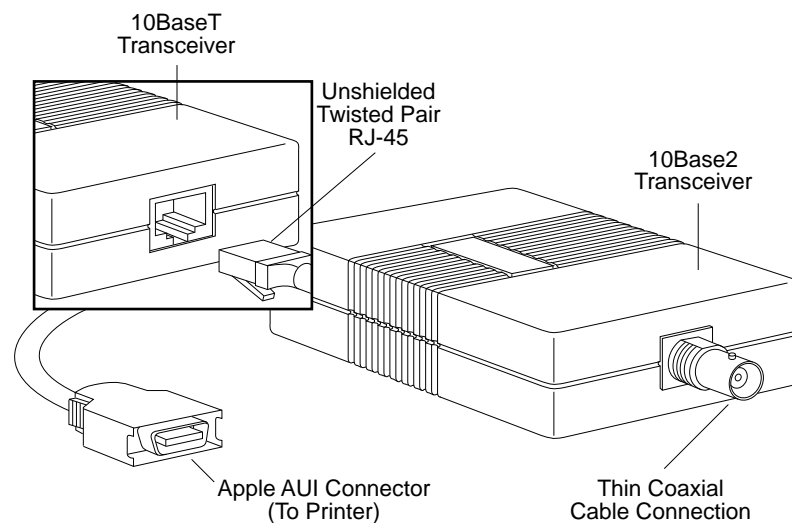

Fig. 2.22 Ethernet Transceivers and Cables

Note: When you connect to an EtherTalk network, you must select EtherTalk Phase 2. Select the phase on your Macintosh through the Network CDEV (Control panel DEVICE) under the Control Panel. The Phase 2 icon usually has two double arrows.

Unshielded Twisted Pair (10BaseT) Connection

This configuration uses ordinary wiring for data transmission. UTP requires a hub to which each device (for example the host computer or the printer) is connected. Hubs can be linked together to form a larger network.

A UTP cable looks like ordinary telephone wire. Each end has an RJ-45 plug which looks like a slightly-larger version of the standard telephone plug (fig. 2.22). The UTP cable should be a maximum of 328 ft. (100 m) in length. No cable terminators are necessary.

To connect your printer via the Ethernet port using the UTP method, use the following procedure.

1. Turn off the printer.
2. Plug the transceiver's Apple AUI connector (fig. 2.22) into the Ethernet port on the printer.
3. Plug one end of the UTP cable into the RJ-45 socket on the transceiver, and plug the other end into an RJ-45 socket on the network's hub.
4. Turn on the printer.

Now that your Macintosh and printer are connected, you may need to set the zone name. For details, skip to "Setting the EtherTalk Zone Name" later in this chapter.

Thin Coaxial Cable (10Base2) Connection

This configuration uses coaxial cable. Thinnet networks connect in a daisy-chain configuration with each of the two ends terminated with either a 50-Ohm terminating resistor or a self-terminating transceiver box. The maximum cable length for a network segment is 607 ft. (185 m). However, devices such as repeaters, routers, and gateways may be inserted to increase the overall length of the network or to connect to other networks.

Thinnet cables usually have a female twist-on BNC connector on each end. A “T” connector is used to tie the external transceiver into the network (fig. 2.23).

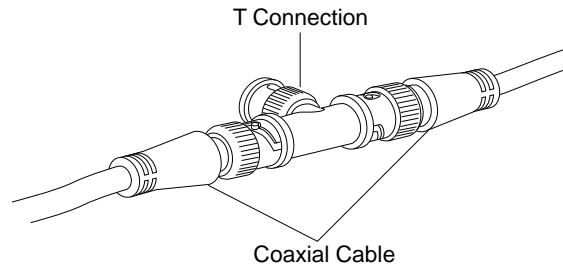

Fig. 2.23 A “T” Connector

Some external transceiver boxes are self-terminating. This means that they do not require a termination resistor if they are the last box on a network. If the box is at one end of a network and not self-terminating, you *must* place a terminating resistor in the open socket.

To connect your printer via the Ethernet port using the thin coaxial cable method, use the following procedure.

1. Turn off the printer.
2. Plug the transceiver’s Apple AUI connector (fig. 2.22) into the Ethernet port on the printer.
3. Connect the transceiver to one end of the coaxial cable. To do this use one of the following procedures:
 - a. If the transceiver box has a single male BNC connector, either plug it into an existing Ethernet drop or use a “T” connector (fig. 2.24). Follow the directions included with the transceiver.

Note: Make sure to place a terminator in the open connector if this is an end node on the network (fig. 2.24).

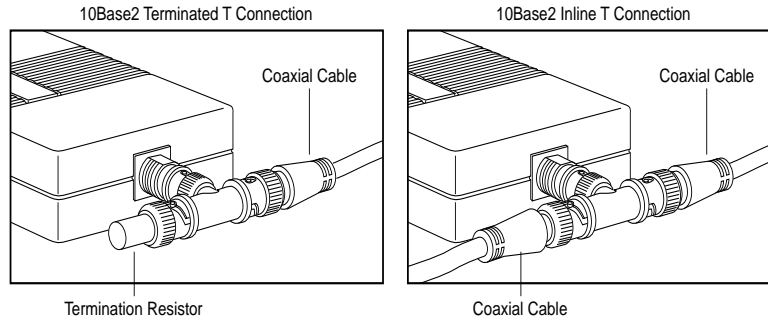

Fig. 2.24 Connecting to a single BNC Connector

- b. If the transceiver box has dual male BNC connectors, first check the documentation to see if the unit is self-terminating. Then, follow the instructions included with the transceiver to attach one end of the coaxial cable to the box.

Note: You can plug the coaxial cable into either one of the male connectors; however, make sure that if this is an end-node on the network and the unit is not self-terminating, that you place a terminator in the open socket on the box.

4. Plug the free end of the coaxial cable into the network.
5. Turn on the printer.

Now that your Macintosh and printer are connected, you may need to set the zone name. For details, see the next section.

Setting the EtherTalk Zone Name

If you need to set the EtherTalk zone name to a name other than the default name supplied by your router, you can do this by creating and downloading a PostScript file to the printer. You can use the Adobe Font Downloader in the XANTÉ Utilities to send this file to the printer.

When you create the file, zone names are limited to 32 characters and should not contain the equal sign (=), the approximately equal sign (\approx), and the asterisk (*). For example, to name your zone “Marketing - First Floor” using the procedure later in this section, you would type the following in step 3.

```
(%EtherTalk_NV%) << /EtherTalkZone (Marketing-First  
Floor) >>setdevparams
```

Note: Check with the system administrator to find out what zone name to use.

To set the EtherTalk zone name, use the following procedure.

1. Open the TeachText program which came with your Macintosh.
2. Select New from the File menu.
3. Type the following file substituting the name for the zone used on your network for `nameofzone`.

```
(%EtherTalk_NV%)<</EtherTalkZone(nameofzone)  
>>setdevparams
```

4. Select Save from the File menu, and save the file as Set Zone.ps on your host system.
5. Select Quit from the File menu to exit TeachText.
6. Insert the Macintosh XANTÉ Utilities disk included with your printer.
7. Open the Utilities folder.
8. Double-click the Downloader icon to open that utility.
9. Choose Download PostScript File from the File menu.
10. Locate the Set Zone.ps file which you created in step 3.

11. Select the Set Zone.ps file and click Download. The following status message appears when the downloading is complete.

The download was successful.

12. Click OK.
13. Select Quit from the File menu.
14. Turn the power to the printer off and on again.

If you need to connect a second host to another printer port, skip to the section on connecting to the desired port in this chapter. If not and you are connecting an optional hard disk, go to the next section “Connecting a Hard Disk.” Otherwise, skip to the next chapter, “Macintosh Setup.”

Connecting a Hard Disk

You can connect multiple hard disks to your printer via the SCSI port. Adding a hard disk increases the available space for font storage. You can download a font to RAM or to a hard disk. However, a font stored in RAM has to be downloaded each time the printer’s power is turned off and on. If you store the font on a hard disk, it remains there until you remove it.

Usually a 20 MB external hard disk is sufficient since this size can hold approximately 500 to 600 extra fonts. However, if you use a large number of fonts, you may want a larger disk or multiple disks.

To connect a hard disk to your printer, you will need a SCSI peripheral cable (25-pin to 50-pin). If the disk is not internally terminated, you also will need an external SCSI terminator. See the hard disk documentation for termination characteristics.

Caution: You need to assign an identification number to your hard disk. Do not turn on the printer or any attached hard disk until the disk has been assigned a number. See your SCSI disk documentation for details on assigning this number.

To connect the hard disk to your printer, use the following procedure.

Caution: DO NOT confuse the serial and SCSI interface ports when connecting cables. This will cause permanent printer damage which is not covered under the warranty. The printer ports are labeled clearly.

1. Make sure the printer and the hard disk are turned off.
2. Connect the SCSI cable following the instructions included with the hard disk.
3. Turn on the hard disk first and wait a few seconds for the hard disk to “spin up.”
4. Turn on the printer.

Once you have connected the hard disk to your printer, use the procedure in the following section to initialize the hard disk.

Initializing a Hard Disk

External hard disks are identified by device numbers such as the example in figure 2.25. Some disks may have a preassigned number or you may need to assign it. See the hard disk documentation for details.

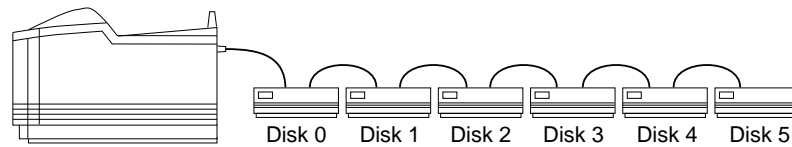

Fig. 2.25 Hard Disk Device Numbers

Caution: Initializing a disk erases all information stored on it. When initializing, make sure you choose the correct device number for the hard disk.

If you are working in a PC environment, skip to “Initializing a Hard Disk with the PC.”

Initializing a Hard Disk with the Macintosh

You can initialize the hard disk in a Macintosh environment by creating a PostScript file to initialize the disk, and then downloading this file to the printer’s external hard disk using the Adobe Downloader in the XANTÉ Utilities.

Caution: Make sure the printer is selected in the Chooser before initializing a hard disk.

Use the following procedure to create the initialization file.

Note: Some XANTÉ Utilities versions have an Initialize disk.ps file. If you have and use this file and have more than one external hard disk attached to your printer, open the file in TeachText and make sure the desired disk is specified. This sample file initializes disk #1. To initialize another disk, substitute the 1 in (%disk1%) with the SCSI ID of the disk you want to initialize. For example, to initialize disk 4, change (%disk1%) to (%disk4%) in step 3.

1. Open the TeachText program which came with your Macintosh system.
2. Select New from the File menu.
3. Type the following initialization file.

```
serverdict begin 0 exitserver
statusdict begin
(%disk1%) 0 1 devformat
end
```

Note: If you are initializing a disk other than disk number one, be sure to substitute the 1 in (%disk1%) with the SCSI ID number of the disk you want to initialize.

4. Select Save from the File menu, and save this file as Initialize Disk.ps on your host system.

5. Select Quit from the File menu to exit TeachText.
6. Insert the Macintosh XANTÉ Utilities disk included with your printer.
7. Open the Utilities folder.
8. Double-click the Downloader icon to open that utility.
9. Choose Download PostScript File from the File menu.
10. Locate the Initialize Disk.ps file which you created in step 3.
11. Select the Initialize Disk.ps file and click Download. Initializing takes time, so be patient. The following status message appears when the initializing is complete:

`The download was successful.`
12. Click OK. Then, select Quit from the File menu.

Note: Turn on the hard disk before turning the printer on whenever you start your system. This ensures that the printer recognizes the hard disk. If the start-up page is enabled, the last line indicates if the hard disk is connected by listing the disk number and size.

Initializing a Hard Disk with the PC

You can initialize the hard disk in a PC environment by creating the following PostScript file and then downloading this file to the printer's external hard disk using the downloader in the XANTÉ Utilities.

Use the following procedure to create the initialization file.

Note: Some XANTÉ Utilities versions have an INITDSK.PS file. If you have and use this file and have more than one external hard disk attached to your printer, open the file in a DOS editor and make sure the desired disk is specified. This sample file initializes disk #1. To initialize another disk, substitute the 1 in (%disk1%) with the SCSI ID of the disk you want to initialize. For example, to initialize disk 4, change (%disk1%) to (%disk4%) in step 2.

1. Open any DOS editor, such as Edlin or DOS Edit (see your DOS or the editor documentation for details).
2. Create a new file by typing the following:

```
serverdict begin 0 exitserver
statusdict begin
(%disk1%) 0 1 devformat
end
^D
```

Note: If you are initializing a disk other than disk number one, be sure to substitute the 1 in (%disk1%) with the SCSI ID number of the disk you want to initialize.

3. Save the file as INITDSK.PS.
4. Send the INITDSK.PS file to your printer by typing either

```
COPY INITDSK.PS LPT1 ↵
```

to download to the printer over the parallel interface, or by typing

```
COPY INITDSK.PS COM1 ↵
```

to download to the printer over the serial interface.

Note: Turn on the hard disk before turning the printer on whenever you start your system. This ensures that the printer recognizes the hard disk. If the start-up page is enabled, the last line indicates if the hard disk is connected by listing the disk number and size.

◇◇◇

